

External Dimensions (mm)

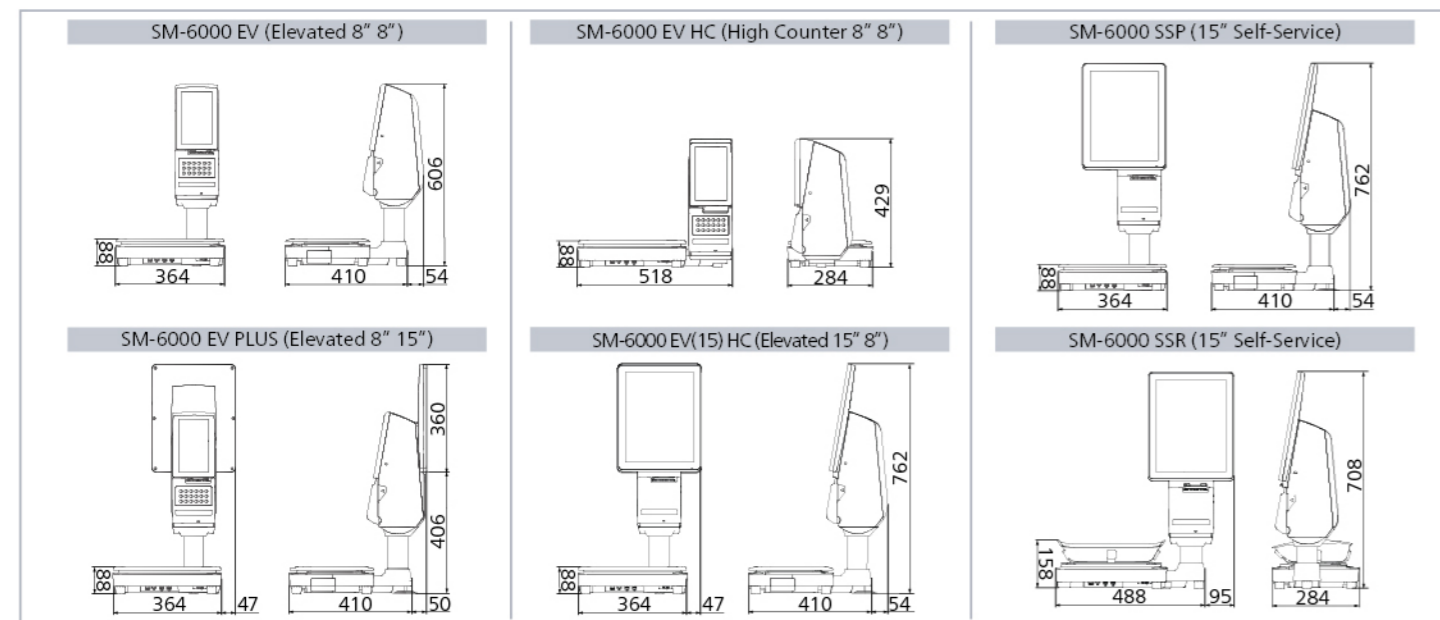

Specifications

Capacity	Max 6kg	Max 15kg / 30lb	Max 30kg
Single Interval	e = 2g	e = 5g / 0.01lb	e = 10g
Capacity	Max 3 / 6kg	Max 6 / 15kg	Max 15 / 30kg
Multi Interval	e = 1 / 2g	e = 2 / 5g	e = 5 / 10g

Model	SM-6000 EV (Elevated 8\"/>									
Dimension WxDxH(mm)	364x464x606	411x460x766	411x464x762	411x460x766	518x284x429	636x284x459	586x284x576	364x464x762	515x284x549	583x284x708
Operator Display	8\"/>									
Customer Display	8\"/>									
Display Resolution	1 / 3,000, 1 / 6,000 & 1 / 7,500									
Keyboard	18 x Keypad (For 8\"/>									
Types	Linerless With Auto-Cutter									
Roll Diameter	Max 95mm									
Label / Print Width	Max 60mm									
Receipt Paper Width	Max 62mm									
Printing Speed	Max 150mm / second*									
Print Resolution	300 dpi									
Power Source	Compiled to 80PLUS Power Saving**									
Operating Temperature	-10°C to +40°C									
Humidity	15% to 85% RH Non-Condensation									
Standard Interface	Ethernet 10 / 100 Base T, 4 x USB 2.0, RJ11									
Net Weight	13.3 kg	14.9 kg	14.9 kg	17.4 kg	12.5 kg	14.1 kg	14.1 kg	14.9 kg	13.7 kg	15.6 kg

Options: Wireless LAN IEEE 802.11 a / b / g / n / ac, e.Label with Hi-Touch, InfoTag, e.Sense, Queue Printer, Base Station
 Factory Option: 2nd Receipt Printer except all the PC Based Self-Service System Scale Printer, Auto Tilt Sensor, Speed ID

* To achieve maximum print speed, high sensitivity thermal paper is necessary.
 ** 100-120Vac Gold (North America, Canada and Japan)
 210-240Vac Silver (European, UK and most of Asia)

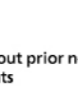
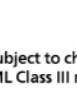
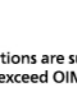
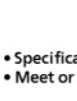

DIGI SINGAPORE PTE. LTD.
 4 Leng Kee Road #05-02 / 03 / 04 / 05 / 11 / 12
 SIS Building SINGAPORE 159088
 TEL : +65 6472 2996
 SALES: +65 6378 5387
 FAX : +65 6863 4614
 URL : www.digisystem.com/sg/
 E-MAIL: customer_support@sg.digi-group.com

TERAOKA SEIKO Co., Ltd.
 13-12 Kugahara 5-chome, Ohta-ku,
 Tokyo 146-8580, JAPAN
 TEL: +81-3-3752-2131
 FAX: +81-3-3752-5562
 URL: www.digisystem.com

SM-6000 / G / 0120



SM-6000

Be Free From Limits



SM-6000 EV



SM-6000

Searching for a New Balance



Accurate, timely pricing and promotional updates are made possible wirelessly with ESL. Developed using ePaper, the high contrast display ensures the best readability for your customers.

InfoTag..

Electronic Shelf Label



Speed ID deploys near field identification technology. SM-6000 is built in with the NFID reader that automatically detects the operator or supervisor. It allows various levels, of access to the scale database and is able to generate a operation log for further analysis.

speedID

Intelligent Clerk Recognition



By omitting the backing paper, the number of labels per roll is increased significantly. Operation downtime for changing of label rolls is also reduced.

Linerless Labeling

Flexible Label Design with Auto-Cutter



Replacing preset keys, remote Hi-Touch PLU System allows operators to call up PLU codes quickly and easily in 3 simple steps.

- Step 1: TAP
- Step 2: WEIGH
- Step 3: PRINT

Hi-Touch

Hi-Touch PLU System

Integrated Solutions

waste management

Reduce Food Wasteage

SM-6000 provides a convenient means to manage and minimise food wastage to protect business margin. Meaningful reports can be generated to help you better match customer demands with inventory.

e.Sense

Intelligent Product Call Up

e.Sense comes with a built in sensor that is triggered by motion to transmit the PLU code to the scale. This can be installed on container or dispenser for accurate PLU call up, eliminates error and reduce shrinkage for customer.

Qmanagement

Manage Queue Status Efficiently

A systematic way to shorten waiting time and faster customer service, resulting in improved customer retention a more efficient operation and increased profits.

- Conventional or mobile queue app
- Single or multiple department queue

eLabel..

Seamless Price Updates

- Dust and water resistant
- Compatible with all DIGI PC based scales
- Efficient and responsive PLU call-up
- Operation temperature: 0°C to 40°C
- Available in 1.54", 2.7" and 4.2" display sizes

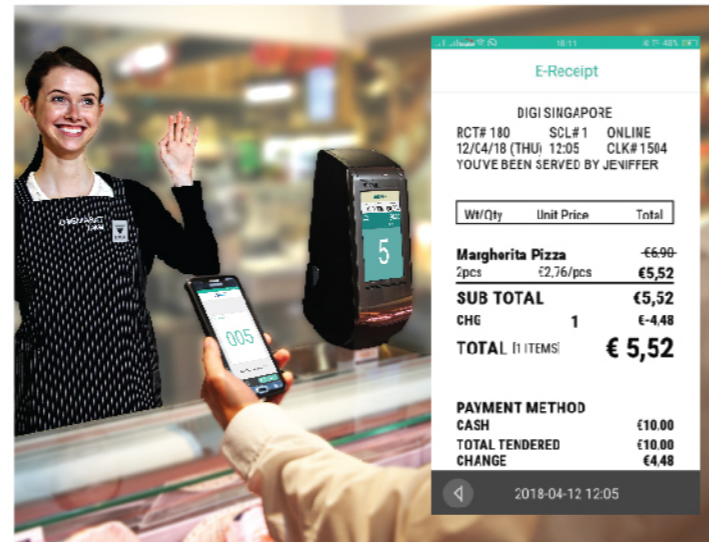

Be Free From Limits

Free up your time, space & status quo



8" Operator Display

Base Station

Swift: operations speed up to 8 times* faster

Notification Alerts

- Announcements from head office
- Critical issues from machines
- Queue status

Capacitive Touch Screen

Responsive touch sensitive screen for operator use

Anti-Stick Operator's Display

Leaves no sticky residue from labels

Linerless Label Printer with Auto-Cutter

Flexible label design print

Haptic Keypad

10 numeric keys and 8 function keys

Speed ID

Hassle-free login

Power Saving

Certified with 80PLUS Gold and Silver power saving

DMC

DIGI Management Console

- Centrally manage scale data and label design in real time
- Tool for remote services software updates and network wide configuration
- Boosts accuracy and efficiency of data maintenance and store operation
- Minimise downtime

Low-Profile Platter

Repetitive actions made comfortable and effortless